

INSTALLATION MANUAL:

COR-1709102 / 1809102

Jeep Wrangler OVERLAND+ and PREMIUM
Short Rear Lower Control Arms
(2007-2018 JK, 2018+ JL)



INCLUDED ITEMS

1709102 Jeep Wrangler OVERLAND+ Short Rear Lower Control Arms - (2007-2018+, JK/JL)

QTY	Part Number	Description	Class/Grade
2	1709102	Short Rear Lower Control Arms	N/A

1809102 Jeep Wrangler PREMIUM Short Rear Lower Control Arms - (2007-2018+, JK/JL)

QTY	Part Number	Description	Class/Grade
2	1809102	Short Rear Lower Control Arms	N/A
2	18951	9/16"-18 x 4" Yellow Zinc Finish Hex Cap Screw	Grade 8
2	37310	9/16"-18 Zinc Finish Top Lock Nut	Grade C
4	33818	9/16" Yellow Zinc Finish SAE Flat Washer	Thru-Hardened

Product Notes and Features:

OVERLAND+ Series:

- Maintenance-free, dual-durometer design isolates road noise for a quieter ride.
- Self-centering with 26.6 degrees of total articulation, ensuring smooth suspension movement.
- Teflon-infused inner surface acts as a bearing for long-lasting performance.

PREMIUM Series:

- Reliable, greaseable, and rebuildable design for unmatched comfort and reliability
- 40 degrees of total misalignment, performing best in off-road conditions
- Smooth and quiet performance

COR-1709102



COR-1809102



CONTROL ARM OVERVIEW

Please review the following information so you can become familiar with our purchasable options



OVERLAND PLUS

Designed for the daily driver/weekend warrior. Features dual-durometer, maintenance-free bushings for comfort on-road and capability on the trails. One of our two available suspension systems that utilize a unique arm design for perfecting suspension geometry. Fully adjustable, 100% bolt on, and Made-In-The-USA with a Lifetime Warranty.



PREMIUM SERIES

Designed for the off-road enthusiast. Features both maintenance-free bushings and forged Johnny Joint adjusters for maximum versatility and flex. One of our two available suspension systems that utilize a unique arm design for perfecting suspension geometry. Fully adjustable, 100% bolt on, and Made-In-The-USA with a Lifetime Warranty.

DISCLAIMER

WARNING:

Suspension systems and their components are designed to enhance your vehicle's off-road performance. This may cause your vehicle to handle differently, on and off-road. Always wear your seatbelt and take extra care when driving a modified vehicle. Failure to do so can result in loss of control which may result in a rollover causing serious injury, or even death to the driver and/or passengers of the vehicle. Regular maintenance and consistent inspections are required to keep your modified vehicle safe and functioning properly. These suspension systems and any components should be installed by certified technicians only. Attempts to install these products without proper knowledge can lead to poor performance, or possible failure, which may jeopardize the safety of the vehicle and its passengers. The installer is responsible for proper installation ensuring a safe and properly functioning vehicle. Take extra care when operating a modified vehicle and thoroughly inspect your vehicle before and after every off-road use.

Read the instruction set in its entirety before attempting the installation.

NOTE:

This product may require general welding, fabrication, and automotive mechanic skills. Welding should only be done by a competent welder. Clayton Off Road implies no guarantees or warranties and is not liable for improper installation. Some grinding and fitment may be required when installing this product. Every vehicle varies slightly, and some fabrication and/or modification may be required.

ATTENTION:

It is the customer's responsibility to thoroughly inspect all received parts to ensure they are assembled correctly and fully welded. Please carefully examine all weld seams and verify that bolt-through holes are properly aligned. Some Clayton Off Road products are permanent, non-removable, weld-on solutions. **If a defect or issue is found after installation, especially with permanent weld-on components, it may be difficult or impossible to correct.** Inspecting the part(s) received beforehand helps prevent unnecessary and avoidable complications.

ATTENTION: TORQUE SPECIFICATION

When working on any vehicle, it is good practice to torque suspension/weight-bearing components while the vehicle is resting under its load. This instruction set, as well as any other Clayton Off Road instruction set, assumes the installer will tighten any suspension-related components properly, to the recommended torque specification, when the vehicle is resting safely under its own weight.

INSTALLATION INSTRUCTIONS

Take this product to a licensed professional if you are hesitant about the installation process!

The following instructions apply to the listed components below:

- Short Rear Lower Control Arms (OVERLAND+ or PREMIUM)

This guide applies to both OVERLAND+ or PREMIUM Control Arms, unless noted otherwise.

We strongly recommend having basic mechanic's hand tools, sockets, wrenches, vehicle jacks and stands, and other common tools readily available. Installing an aftermarket lift kit is a detailed process, and having the right tools on hand will ensure a smoother installation.

As always, feel free to contact us at any point during your installation - you can count on us to help!

COR-1709102

1709102 Installation Tools Required:

- 21mm socket/wrench
- Impact drill
- Vehicle jack and stands
- Torque wrench
- Large adjustable wrench (OR 1-7/8")

COR-1809102

1809102 Installation Tools Required:

- 21mm socket/wrench
- Impact drill
- Vehicle jack and stands
- Torque wrench
- Large adjustable wrench (OR 1-7/8")

CONTROL ARM LENGTHS

Please refer to Table 1 below for minimum and maximum control arm lengths. These lengths are absolute and should only serve as limits for axle positioning and dialing in pinion/caster angle. **All the following measurements are given as "eye-to-eye" lengths (center-to-center of joints).** Do not exceed the maximum lengths recommended for any suspension component. Should you require custom control arms with unique lengths, please contact us.

Please note that your exact arm length will vary by lift height. Refer to Table 2 for recommended starting points based on your lift height. These are **NOT** intended as final measurements. Due to many variables, final adjustments should be made once all components are installed, then fine-tuned for your specific vehicle.

Table 1: COR-1709102 / 1809102 Minimum and Maximum Arm Lengths

Control Arm Type / Series	Minimum	Maximum
1709102 OVERLAND+ Short Rear Lower Arms	$19 - \frac{9}{16}$ "	$21 - \frac{1}{8}$ "
1809102 PREMIUM Short Rear Lower Arms	$19 - \frac{13}{16}$ "	$20 - \frac{9}{16}$ "

Table 2: COR-1709102 / 1809102 Arm Lengths by Lift Height

Vehicle Make/Model/Year	1.5" Lift	2.5" Lift	3.5" Lift	4.5" Lift
4-Door Jeep JL (2018+) 2-Door Jeep JL (2018+)	20"	20"	20"	20"
4-Door Jeep JK (2007-2018) 2-Door Jeep JK (2007-2018)	20"	20"	20"	20"

INSTALLATION INSTRUCTIONS

Take this product to a licensed professional if you are hesitant about the installation process!

1. If you are just installing lower control arms, they can be replaced one at a time with the vehicle sitting on level ground, without removing the wheels, tires, or any other suspension component.

Start on the driver's side and remove the rear lower control arm using a 21mm socket and wrench. Remove the frame bolt first. You may jack the vehicle up slowly by the frame to remove the axle-side bolt if it is stuck.



Jeep JL on two-post lift for installation



Jeep JL rear lower control arm mounts (axle and frame)

INSTALLATION INSTRUCTIONS

2. Determine the appropriate length of the new rear lower control arms based on your vehicle's ride height and your desired pinion and caster angles. Use the lengths provided at the beginning of these instructions as a starting point.

Adjust the end-forging by screwing it in or out. **Measure the length from eye-to-eye, or center of bushing to center of bushing.** When the desired length is met, spin the jam nut down to the control arm to lock the forging into position.

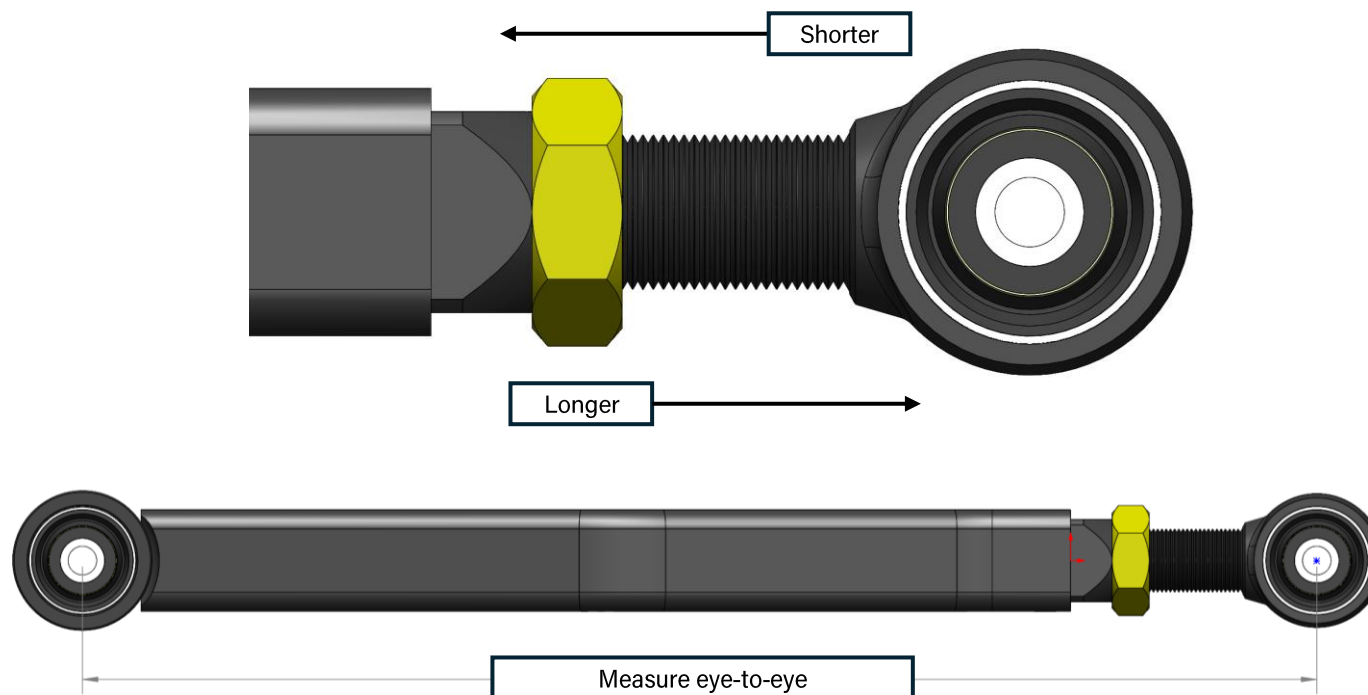

INSTALLATION INSTRUCTIONS

3. Install the new lower control arm with the adjuster end at the frame-end. Use factory hardware, unless noted otherwise. See photos below for proper control arm orientation. Tighten the hardware, but do not torque yet.

*****1809102 HARDWARE NOTE*****

Use the supplied 9/16"-18 bolt and hardware at the frame-end mount (Johnny Joint)

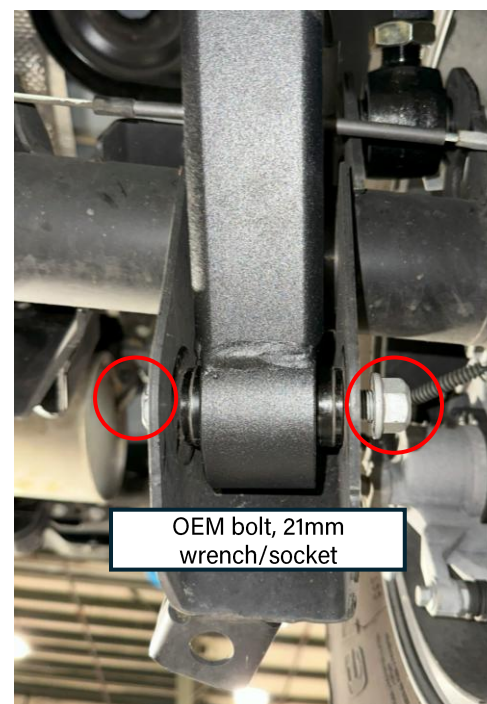

1709102 (OVERLAND+ Series) Rear lower control arm installed (frame-end and axle-end)

INSTALLATION INSTRUCTIONS

- Repeat Steps 1-3 for the other rear lower arm. Make sure that the lower arms are the same length. Also, confirm that the adjuster is at the frame-end, not the axle-end.

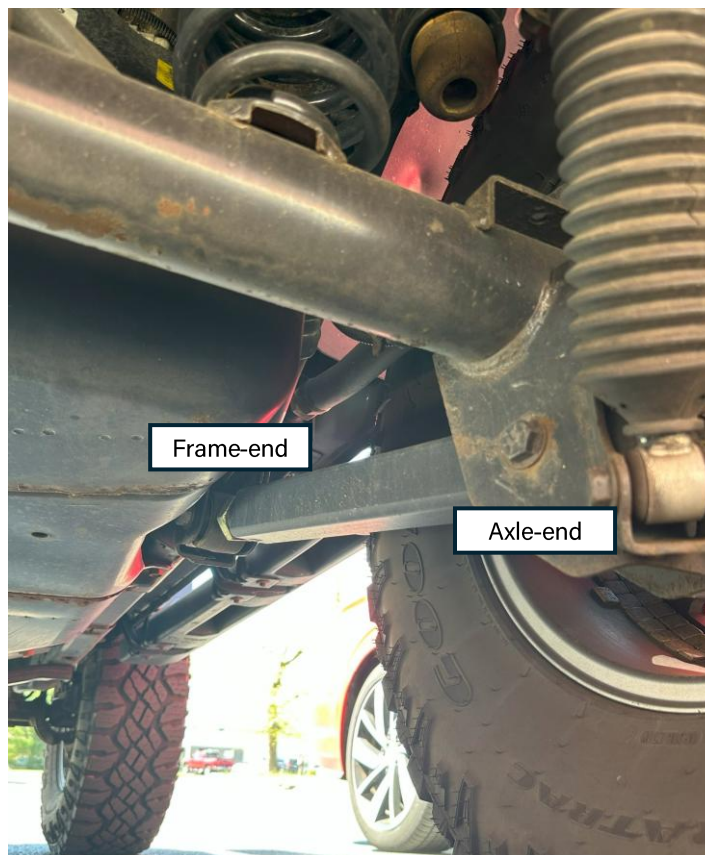

1709102 (OVERLAND+ Series) Rear lower control arm installed, passenger-side (Jeep JK)

INSTALLATION INSTRUCTIONS

5. Return the vehicle to the ground. Torque both lower control arm bolts to **125 ft-lbs using a torque wrench.**

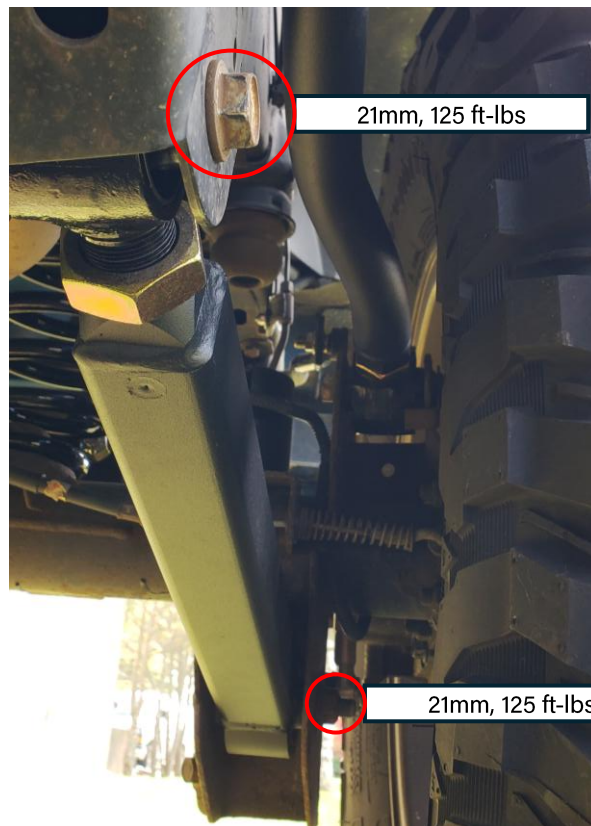

1709102 (OVERLAND+ Series) Rear lower control arm installed on Jeep JK

INSTALLATION INSTRUCTIONS

6. Tighten down the jam nuts on the upper and lower control arms. Use a 1-7/8" wrench for the lower control arm jam nuts, and a 1-1/2" wrench for the upper control arm jam nuts. Use a breaker bar to gain additional leverage. Tighten all jam nuts down as tight as humanly possible.

Please note that not all wrenches are created with the same tolerances. If your wrenches are too loose around the jam nut, Clayton Off Road offers tight, wrap-around wrenches for purchase. Please search for the wrenches using the SKU's below.



COR Wrench-ends for control arm jam nuts (COR-2500125, COR-2500100)

INSTALLATION INSTRUCTIONS

7. The installation is now complete. Please follow the post-installation checklist below before driving your vehicle.



POST-INSTALLATION CHECKLIST:

- Rear lower control arm bolts (axle and frame) are torqued to 125 ft-lbs
- Lug nuts are torqued to the manufacturer's specification (if removed)
- Jam nuts are jammed down as tight as possible
- The vehicle is properly aligned by a professional for adjusting your caster and aligning the suspension

